



T400E MANUAL

**Models
T4004V46CAI
T4004V4CAI**

**Important: This document should be read carefully before commencing
installation**

Rev2 Sept 2009

CONTENTS

INTRODUCTION

1 SPECIFICATIONS

- 1.1 CONTROL UNIT
- 1.2 BEARING TEMPERATURE SENSORS

2 INSTALLATION INSTRUCTIONS

- 2.1 CONTROL UNIT
- 2.2 BEARING TEMPERATURE SENSORS

3 ELECTRICAL WIRING

4 OPERATING INSTRUCTIONS

- 4.1 THE TEST FUNCTION
- 4.2 NORMAL OPERATION
- 4.3 HOT BEARING ALARM
- 4.4 ALARM MUTE
- 4.5 HOT BEARING STOP (SHUT DOWN)
- 4.6 RESTARTING

5 FAULT FINDING

DRAWINGS

- A BLOCK DIAGRAM AND SENSOR WIRING
- B SUPPLY AND RELAY WIRING
- C FITTING OF TEMPERATURE SENSOR TO BEARING



Dear 4B Customer:

Congratulations on your purchase. 4B appreciates your business and is pleased you have chosen our products to meet your needs.

Please read in its entirety and understand the literature accompanying the product before you place the product into service. Please read the safety precautions carefully before operating the product. With each product you purchase from 4B, there are some basic but important safety considerations you must follow to be sure your purchase is permitted to perform its design function and operate properly and safely, giving you many years of reliable service. Please read and understand the Customer Safety Responsibilities listed below. Failure to follow this safety directive and the Operation Manuals and other material furnished or referenced, may result in serious injury or death.

SAFETY NOTICE TO OUR CUSTOMERS

- A. In order to maximize efficiency and safety, selecting the right equipment for each operation is vital. The proper installation of the equipment, and regular maintenance and inspection is equally important in continuing the proper operation and safety of the product. The proper installation and maintenance of all our products is the responsibility of the user unless you have asked 4B to perform these tasks.
- B. All installation and wiring must be in accordance with Local and National Electrical Codes and other standards applicable to your industry. (Please see the article "Hazard Monitoring Equipment Selection, Installation and Maintenance" at www.go4b.com.) The installation of the wiring should be undertaken by an experienced and qualified professional electrician. Failure to correctly wire any product and/or machinery can result in the product or machine failing to operate as intended, and can defeat its design function.
- C. Periodic inspection by a qualified person will help assure your 4B product is performing properly. 4B recommends a documented inspection at least annually and more frequently under high use conditions.
- D. Please see the last page of this manual for all warranty information regarding this product.

CUSTOMER SAFETY RESPONSIBILITIES

1. READ ALL LITERATURE PROVIDED WITH YOUR PRODUCT

Please read all user, instruction and safety manuals to ensure that you understand your product operation and are able to safely and effectively use this product.

2. YOU BEST UNDERSTAND YOUR NEEDS

Every customer and operation is unique, and only you best know the specific needs and capabilities of your operation. Please call the 24-hour hotline at 309-698-5611 for assistance with any questions about the performance of products purchased from 4B. 4B is happy to discuss product performance with you at any time.

3. SELECT A QUALIFIED AND COMPETENT INSTALLER

Correct installation of the product is important for safety and performance. If you have not asked 4B to perform the installation of the unit on your behalf, it is critical for the safety of your operation and those who may perform work on your operation that you select a qualified and competent electrical installer to undertake the installation. The product must be installed properly to perform its designed functions. The installer should be qualified, trained, and competent to perform the installation in accordance with Local and National Electrical Codes, all relevant OSHA Regulations, as well as any of your own standards and preventive maintenance requirements, and other product installation information supplied with the product. You should be prepared to provide the installer with all necessary installation information to assist in the installation.

4. ESTABLISH AND FOLLOW A REGULAR MAINTENANCE AND INSPECTION SCHEDULE FOR YOUR 4B PRODUCTS

You should develop a proper maintenance and inspection program to confirm that your system is in good working order at all times. You will be in the best position to determine the appropriate frequency for inspection. Many different factors known to the user will assist you in deciding the frequency of inspection. These factors may include but are not limited to weather conditions; construction work at the facility; hours of operation; animal or insect infestation; and the real-world experience of knowing how your employees perform their jobs. The personnel or person you select to install, operate, maintain, inspect or perform any work whatsoever, should be trained and qualified to perform these important functions. Complete and accurate records of the maintenance and inspection process should be created and retained by you at all times.

5. RETAIN AND REFER TO THE OPERATION MANUAL FOR 4B’S SUGGESTED MAINTENANCE AND INSPECTION RECOMMENDATIONS

As all operations are different, please understand that your specific operation may require additional adjustments in the maintenance and inspection process essential to permit the monitoring device to perform its intended function. Retain the Operation Manual and other important maintenance and service documents provided by 4B and have them readily available for people servicing your 4B equipment. Should you have any questions, please call the 4B location who supplied the product or the 24-hour hotline number in the USA -309-698-5611.

6. SERVICE REQUEST

If you have questions or comments about the operation of your unit or require the unit to be serviced please contact the 4B location who supplied the product or send your request via fax (309-698-5615), email (4b-usa@go4b.com), or call us via our 24-hour hotline number in the USA - 309-698-5611. Please have available product part numbers, serial numbers, and approximate date of installation. In order to assist you, complete the following information after the product has been placed into service and fax this page to 309-698-5615.

SITE NAME:
SITE LOCATION:
CONTACT NAME:
CONTACT NUMBER:
PART NUMBER:
SERIAL NUMBER:
DATE OF INSTALL:

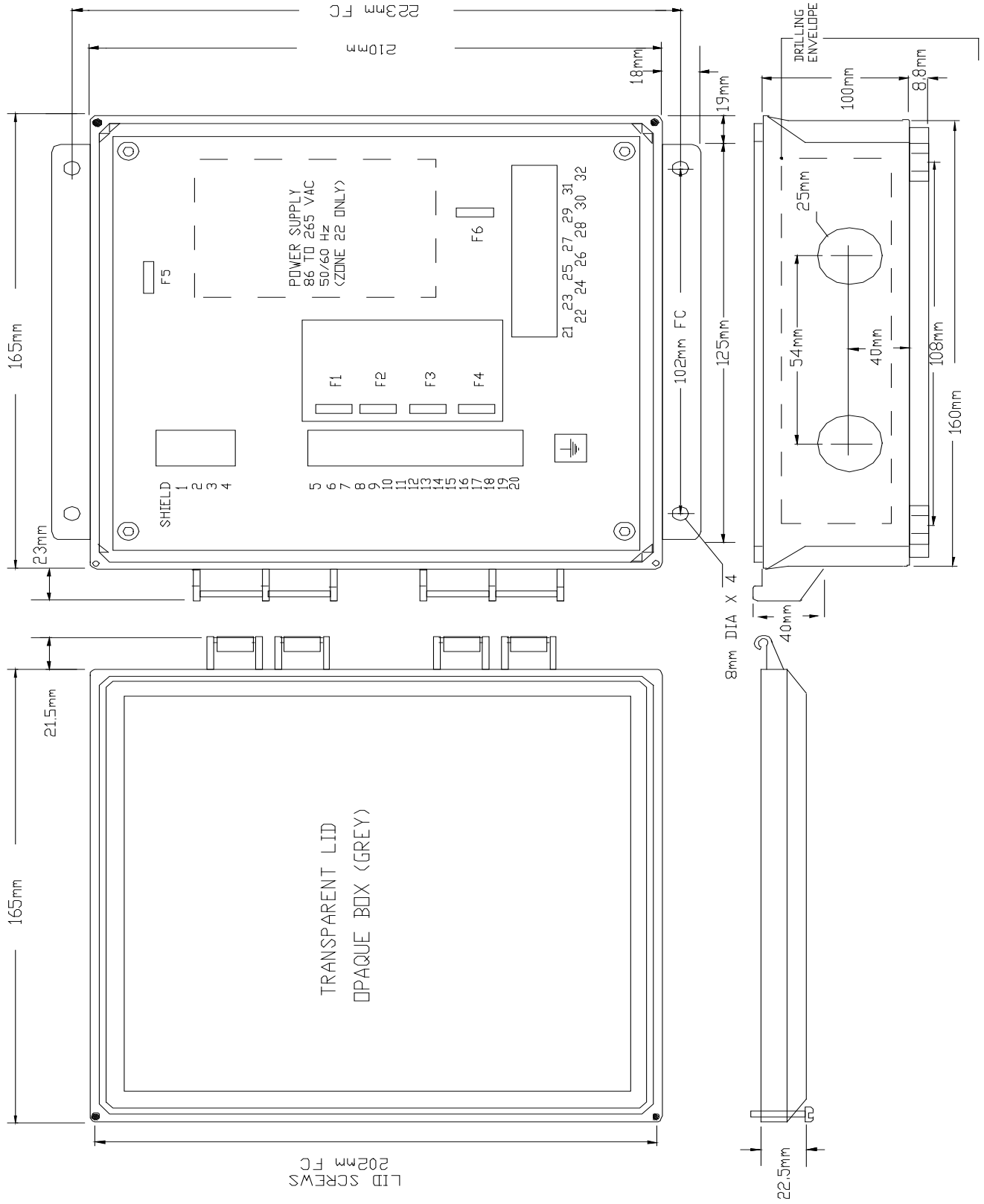

Approvals

Zones of use of T400 Elite:

CAT II 3D for use in Zone 22. Areas as defined in BS EN 50281-1-2

Certification Markings:

CE 1180  II 2D T125° -20°C to +50°C IP66 Basefa04ATEX0131X
DIP DIP A21 TA125°C IP66 -20°C < t <+50°C - IECEx BAS 05.0025X



Class II Division 1 Groups E, F & G (Canada Only)



Class II Division 2 Groups F & G (USA Only)

Power dissipation in Watts

ATEX category 2D : 12 Watts

To Open the Lid:

1. Disconnect power (isolate ALL circuits)
2. Untighten the lid securing screws
3. Carefully open the lid ensuring that the gasket is not damaged and remains in place

To Close the Lid:

1. Check that the gasket is correctly fitted into the box groove and is undamaged.
2. Tighten the lid screws.
3. Check that the lid and box are correctly mated.

Special conditions for safe use:

WARNING: Static Hazard - Clean only with a damp cloth.

T400 ELITE HOT BEARING MONITOR

INTRODUCTION

The T400 ELITE is a microprocessor controlled unit which is able to accept signals of hot bearings in 8 zones and is able to cause alarm and shutdown of the machine when hot bearings are detected. The control unit is housed in a self-contained wall-mounting enclosure, and the sensors are separate items for mounting on the bearings. The T400 ELITE will operate from 100 to 240 VAC $\pm 10\%$ or from 24VDC.

1. SPECIFICATIONS

1.1 The Control Unit

A plastic enclosure houses the electronics and terminal connectors. The unit contains a printed circuit board to accommodate power supply circuitry, output relays, microprocessor and terminals. A short ribbon cable is connected to the lid of the enclosure where the indicator lamps are mounted. Two 'touch buttons' are mounted on the lid to allow the unit to be tested during operation, and to mute the alarm relay.

Electrical Supply (T4004V46CAI) - (T4004V4CAI)	-	24VDC or 100 to 240 VAC $\pm 10\%$ 50/60Hz (Zone 22 only) 24Vdc (Zone 21 only)
Power Consumption	-	12VA/12 WATTS
Alarm Relay Contacts	-	1 Pole normally open 8A@ 250VAC
Stop Relay Contacts	-	1 Pole normally open 8A@ 250VAC
Sensor Inputs	-	PTC thermistor
Sensor Supply	-	24VDC Current 100 ma maximum
Terminals	-	Power 4mm ² 14 AWG max Signals 2.5mm ² 16 AWG max Plug In
Protection	-	ATEX CE Ex II 2D T125°C, II 3D T125°C Class II Division 1 Groups E, F & G (Canada Only) Class II Division 2 Groups F & G (USA Only)
Height	-	9.7", 246mm
Width	-	7.4", 188mm
Depth	-	4", 102mm
Fixing Centres	-	8.75" high x 4" wide, 222mm x 102mm
Cable Entry	-	2 Holes 1 1/8" DIA, 28mm, 3/4" CONDUIT
Weight	-	3lbs, 1.3Kg

- | | | |
|------------------------|---|----------------------------|
| Status Indicator Lamps | - | Viewed through front panel |
| | - | POWER |
| | - | HOT BEARING 1 |
| | - | HOT BEARING 2 |
| | - | HOT BEARING 3 |
| | - | HOT BEARING 4 |
| | - | HOT BEARING 5 |
| | - | HOT BEARING 6 |
| | - | HOT BEARING 7 |
| | - | HOT BEARING 8 |
| | - | ALARM |
| Touch Switches | - | MUTE |
| | - | TEST |

1.2 Bearing Temperature Sensors

1.2.1 Bearing Temperature Sensor – a range are available.

The temperature Sensor is designed to screw into the bearing housing in a grease nipple hole or other tapped hole and will detect excessive temperature of the bearing housing. The body of the sensor contains a positive temperature coefficient (PTC) thermistor which has a fixed switching temperature. Below this temperature, the thermistor has a low resistance and above this temperature it has a very high resistance. All of the sensors in each zone on the bearings are connected electrically in series so that if any one of them exceeds its switching temperature the total resistance exceeds the trip resistance of the control unit. The system fails to safe, as if the wire is broken at one of the sensors, an alarm signal is generated. A two core plus shield cable is permanently attached to the sensor body. A grease nipple is provided in the body of the sensor to allow greasing of the bearing in the normal manner.

SWITCHING TEMPERATURE RANGE

- depending on sensor chosen: 50°C to 90°C + 5°C

SEE INDIVIDUAL BEARING SENSOR MANUALS

- | | | |
|---------------------|---|---|
| RESISTANCE AT 60°C | - | 250 Ohms max |
| RESISTANCE AT 100°C | - | 2000 Ohms Min |
| SENSING VOLTAGE | - | 30V DC maximum |
| SENSING CURRENT | - | 5ma maximum |
| FIXING THREAD | - | 1/8" NPT |
| CABLE | - | 2 Core + shield 0.75mm ² 10ft (3Mtr.) Long |
| WEIGHT | - | 7 oz. (0.2Kg) |

Protection.

Ex II 1 D T_{xx}°C BAS01 ATEX 1191X

CSA Class II Division 1 (WDB2's ONLY)

2 INSTALLATION INSTRUCTIONS

Warning: Always lock-out and tag-out the machine prior to installation and set-up.

Wiring: All Wiring Must Be In Accordance With Local and National Electrical Codes and Should Be Undertaken By an Experienced and Professional, Qualified Electrician.

2.1 The Control Unit

The Control Unit box should be installed in a suitable control or starter switch room and mounted at an eye level position so that the warning lights can be readily seen. The box should have sufficient space to open the lid for wiring and adjustment. An audible alarm, hooter or visual indicator lamp can be installed in or outside of the control room.



The Control Unit is susceptible to static voltage. Connection of a clean ground to terminal 31 is essential for optimum performance. Prior to this connection, static handling precautions should be taken.

Enclosure Installation:

- a. The IP66 rating of the enclosure must be maintained when used in a Zone 21 dust environment. You must use the correct cable, glands and sealing arrangement and in accordance with the installation codes detailed in BS EN 60079 and EN 50281
- b. Where other certified components are used as part of the assembly or installation procedure, the user must take in to account any limitations which might be listed on the relevant certificates.
- c. The box is supplied with 2 x 27.5mm (1¹/₈") pre drilled holes in the bottom face. The user may add **only 2 x 27.5mm (1¹/₈")** clearance holes per face. The holes may be placed anywhere on the box face but the centre line between adjacent holes must be no less than 54mm (2¹/₄). There must be at least 12.7mm (1/2") of material from the inside edge of the box. All unused entry apertures must be sealed using component certified stopping plugs Hawke International type 375 or 387. The end user must install component or apparatus certified stopping plugs and cable glands in strict accordance with the manufacturer's instructions.
- d. The enclosure must not be modified in any way without reference to don Electronics, as this will invalidate the certification, except where used in certain Zone 22 applications.
- e. All wiring must be carried out in accordance with relevant codes of practice and / or instructions (BS EN 600079-14, EN50281).
- f. The voltage and current and maximum power dissipation shown on the box label must not be exceeded.
- g. The wiring installation must extend to within 1 mm of the metal face of the terminal.
- h. All leads must be insulated for the appropriate voltage.

- i. Not more than 1 single or multiple strand cable is to be connected to any terminal unless multiple conductors have previously been joined in a suitable manner (e.g. boot lace ferrule) such that they present a single connection point to the terminal.
- j. A parallel shaft screwdriver of the correct size should always be used when tightening terminals.

2.2 Bearing Temperature Sensors (Grease through type)

The standard temperature sensors, which are pre-set at 80°C are screwed into the grease holes of the bearings for the elevator leg head pulley, boot pulley and jockey pulley, where fitted. If any of the sensors exceeds its switching temperature, a signal is sent to the control unit and will cause an alarm signal, eventually resulting in shutdown. Each sensor has a greasing by-pass and is installed in the bearing as Drawing 'C'.

3 ELECTRICAL WIRING

Refer to Drawings A & B

Mount a conduit junction box within 10ft (3 metres) of each sensor – generally one junction box can be used for a pair of sensors. Connect the sensor cable to the junction box using sealing glands and protect the cable from damage. If flexible conduit is to be used, a conduit adaptor is available to attach to the sensor. Connect the junction box back to the control unit. We strongly recommend the use of shielded wires when wiring the sensors to the control unit. When terminating conduits at the control unit, ensure ground continuity by using a suitable bushing.

Any Bearing Sensor inputs which are unused must be connected to +volts at the control unit.

When installing the equipment in an area which is likely to be hazardous from Ignitable Dusts, use liquid tight conduit and fittings and follow all local codes.
Terminal (Shield) is used to provide a continuous shield connection for the communications cable and is not grounded in the T400

WARNING: under no circumstances must the power supply connection be allowed to come into contact with these terminals; to do so would result in the failure of the communications interface.

Terminal 5 is provides for an 0 volt connection
Terminal 6 is used for temperature sensor 1 input
Terminal 7 is used for temperature sensor 2 input
Terminal 8 is used for temperature sensor 3 input
Terminal 9 is used for temperature sensor 4 input
Terminal 10 is used to provide +24 VDC power to the temperature sensors
Terminal 11 is used to provide +24 VDC power to the temperature sensors
Terminal 12 is used for temperature sensor 5 input
Terminal 13 is used for temperature sensor 6 input
Terminal 14 is used for temperature sensor 7 input

Terminal 15 is used for temperature sensor 8 input
Terminal 16 is provides for an 0 volt connection

Terminal 17 no connection
Terminal 18 no connection
Terminal 19 is used for remote MUTE+ connection
Terminal 20 is used for remote MUTE- connection

Terminals 21 and 22 are no connection

Terminals 23 and 24 are a volt free Alarm contact for Alarm relay A rated 250 VAC @ 8 Amp non inductive.

Terminals 25 and 26 are no connection

Terminals 27 and 28 are a volt free Stop contact for Stop relay A rated 250 VAC @ 8 Amp non inductive.

Terminals 29 and 30 are for the AC power supply. This is only fitted when the T400 is to be used in a Zone 22 application. The AC supply can be between 100 and 250 Volts 50/60 HZ.

Terminal 31 is used for a ground (earth) terminal when using a mains power supply or an 0 VDC terminal when using a separate DC power supply.

Terminal 32 is used when powering the T400 from a separate 24 VDC power supply.

Fuses:

It is very important to observe the fuse ratings used on the T400 elite. The following fuse ratings **MUST** apply.

F5 has a recommended maximum rating of 200mA when used in a CAT 2D (Zone 21) installation.

F5 has a recommended maximum rating of 1A when used in a CAT 3D (Zone 22) installation.

F5 is used to limit the current available to the internal electronics and terminals 3 and 4.

F6 is used to protect the AC power supply and should have a 1.0 Amp rating. In order to maintain the product certification, these fuses **MUST** be replaced with equivalent fuses at the same rating. Failure to do so will invalidate the certification and any warranties which may exist. The sensor supply (terminals 10 and 11) is limited by F5.

4 OPERATING INSTRUCTIONS

4.1 The TEST function

4.1.1 Normal Test

The T400 ELITE is equipped with a self test function, initiated by the test touch button on the lid of the control unit. When the button is touched sensor 7 lamp flashes and then the following automatic test is initiated as the touch is released.

1. All lamps illuminate – sensor 7 lamp continues to flash
2. After 5 seconds all lamps return to their pre-test conditions

This test can be performed when the system is running or stopped and tests the correct function of the microprocessor and of all lamps.

4.1.2 Extended Test

If the Normal Test is initiated as in 4.1.1 and if the test touch button is touched again, while sensor 7 lamp is flashing, the extended test operates as follows:

1. All lamps illuminate – sensor 7 lamp continues to flash
2. Touching the test sensor again
3. Sensor 7 and 8 lamps flash together for a further 5 seconds (8 seconds total time)
4. The ALARM RELAY and STOP RELAY are inverted (off becomes on and on becomes off) and sensor 7, sensor 8 and the alarm led flash together.
5. After 3 seconds all lamps and relays return to their pre test conditions

If this test is performed when the system is not running, the Alarm will sound but the STOP RELAY will have no effect on the equipment. If this test is performed when the equipment is running, the Alarm will sound and the STOP RELAY will stop the equipment! This test should be performed on a regular basis to check the safety of the installation.

The touch button has been designed to ignore the first 0.5 seconds of touch; this is to reduce the possibility of accidental activation. Once activated as indicated by the led adjacent to the touch pad, removing the finger deactivates the button, if you leave your finger in place, the touch button will only remain active for approximately 2 seconds before automatically de-activating again. The touch button continuously recalibrates in order to eliminate the effects of static, dust or moisture build up on the surface.

4.2 Normal Operation

If all Hot Bearing Sensors are ‘cold’, all eight HOT BEARING indicator lamps will be off. The ALARM indicator lamp and ALARM relay will be off. The STOP relay will be energised.

4.3 Hot Bearing Alarm

If a Hot Bearing Sensor becomes 'hot', the associated HOT BEARING indicator lamp and ALARM lamp will illuminate. After approx 2 seconds, the ALARM relay will energise. If the Hot Bearing Sensor then becomes 'cold', the HOT BEARING indicator lamp, ALARM lamp and ALARM relay will de-energise.

If more than one Hot Bearing Sensor becomes 'hot', all associated HOT BEARING indicator lamps will illuminate. Only when all Hot Bearing Sensors become 'cold' will the ALARM lamp and ALARM relay de-energise.

4.4 Alarm Mute

If the ALARM lamp and ALARM relay are energised because of a Hot Bearing, the ALARM may be muted (turned off) by the following methods. If a finger is placed on the MUTE target, the ALARM lamp begins to flash, the ALARM relay de-energises and all HOT BEARING indicator lamps which were illuminated will flash. Alternatively, if a voltage is applied to the MUTE input terminals, the same MUTE action will occur. If the Hot Bearing Sensors become 'cold', the flashing indicator lamps will de-energise.

If, during a MUTE condition, a further bearing sensor becomes 'hot', the associated HOT BEARING indicator lamp will illuminate, the ALARM lamp and relay will energise leaving the original muted HOT BEARING indicator lamps flashing. A further MUTE operation would flash all associated HOT BEARING indicator lamps.

4.5 Hot Bearing Stop (Shut Down)

If a HOT BEARING condition is detected, and if the ALARM indicator lamp is on (whether muted or not) for more than 3 minutes, the STOP relay will de-energise. If the ALARM condition is cleared in less than 3 minutes, the STOP relay will not de-energise but the amount of alarm time will be 'remembered'. If the ALARM condition occurs again immediately, the 'shut down timer' will continue from where it last stopped until the 3 minutes is completed. If the ALARM condition does not occur again immediately, the 'shut down timer' will time backwards, reducing the amount of time 'remembered' until the timer reaches zero. Consequently, if the alarm condition is intermittent, but no single interval of alarm exceeds 3 minutes, the persistence of alarms can eventually result in a STOP condition.

4.6 Restarting

If the machine has stopped because of a hot bearing condition as in 4.5 the lamps described above will remain flashing indefinitely. As soon as the hot bearings have cooled the flashing lamps will be cancelled, and the ALARM and STOP relays will be reset.

CHECKLIST
For problems after initial start-up

1. Is there excessive interference on the electrical power supply? Power conditioners and surge (spike) suppressor may have to be fitted.
2. Has the wiring for the Sensors been routed away from power cables? See paragraph 3.
3. Is the T400 Elite circuit properly grounded?
4. Is the Micro-processor control unit overheating, if so mount in temperature-controlled environment of maximum temperature 40°C.
5. Check that high powered 'Walkie Talkie' radios are not operated immediately near the T400 Elite control unit or Sensors as this will affect the performance.

5. FAULT FINDING CHART

SYMPTOM	CAUSE	REMEDIAL ACTION
Hot Bearing LED on Control Unit does not illuminate	Sensor not operating Wiring Fault Sensor connected to wrong terminals	Replace Sensor Check wiring
Hot Bearing LED on Control Unit on continuously	Wiring fault Sensor fault Unused input	Check wiring Check sensor Connect to +v
Wrong Hot Bearing LED on unit illuminates	Sensor connected to wrong input	See drawing 'A'
Alarm LED on	Bearing is HOT	Check Bearings
Relay off	Stop condition occurred	Alarm condition for more than 3 minutes
Machine fails to start	Wiring fault	Check wiring



www.go4b.com

For further information.

Manufactured by **Don Electronics Limited.**

Westfield Industrial Estate

Kirk Lane, Yeadon

Leeds LS19 7LX

Tel +44(0)845 130 4798

Web: www.donelectronics.co.uk

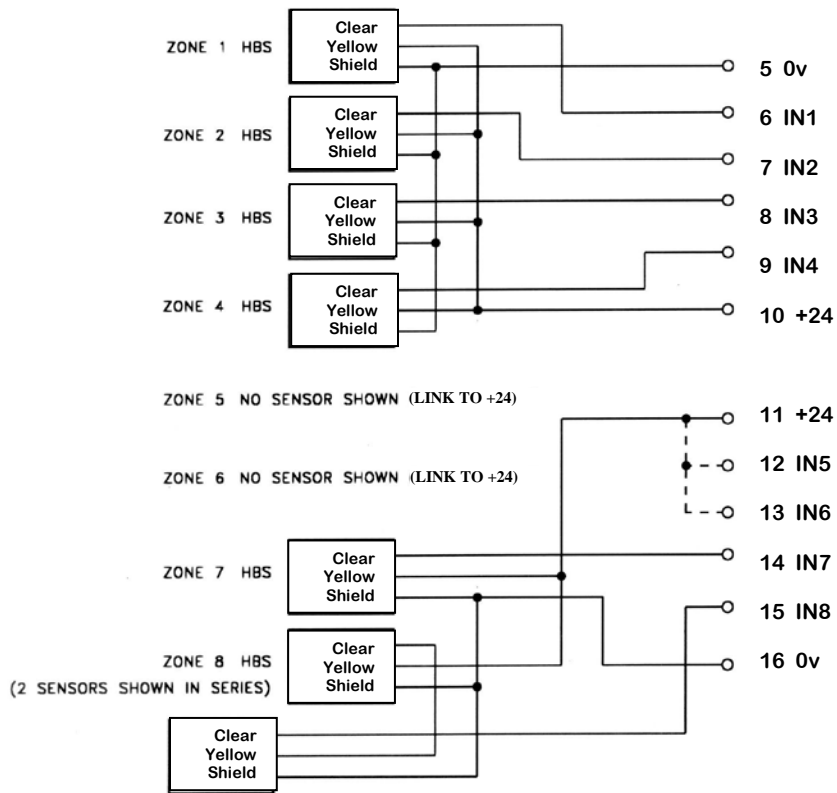
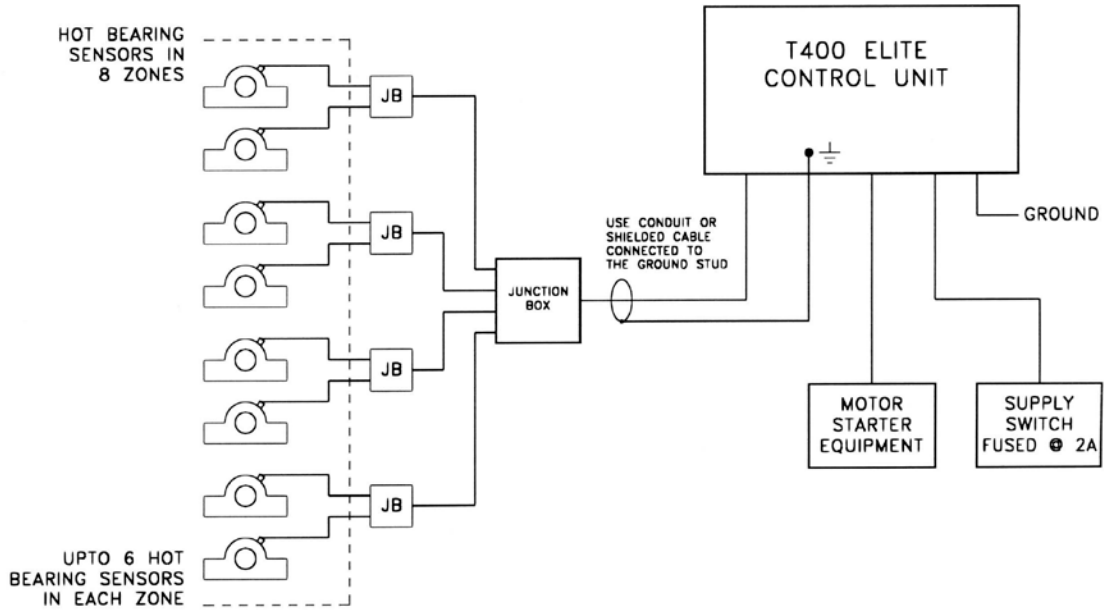

BLOCK DIAGRAM AND SENSOR WIRING

DRG.'A'

AC SUPPLY

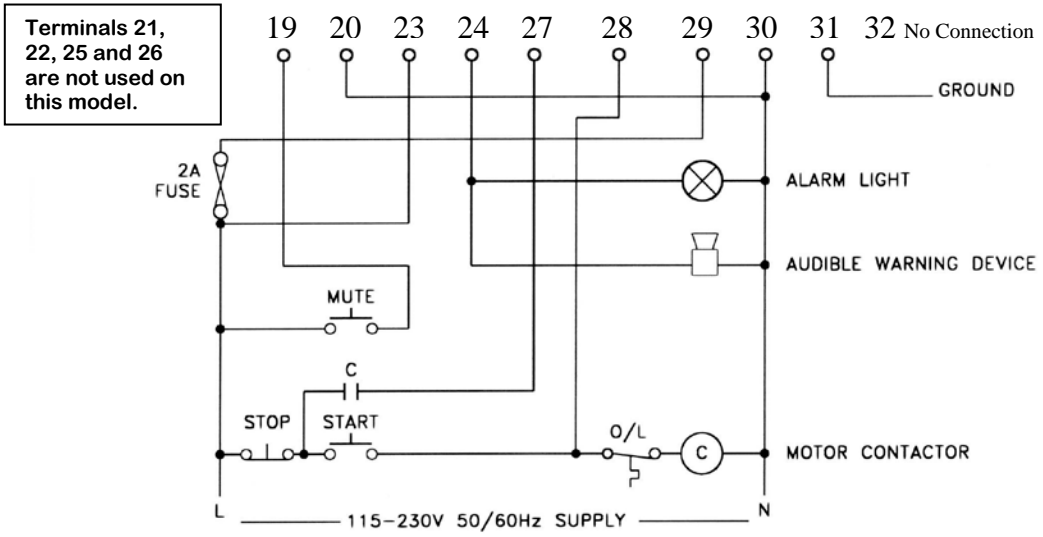

DC SUPPLY

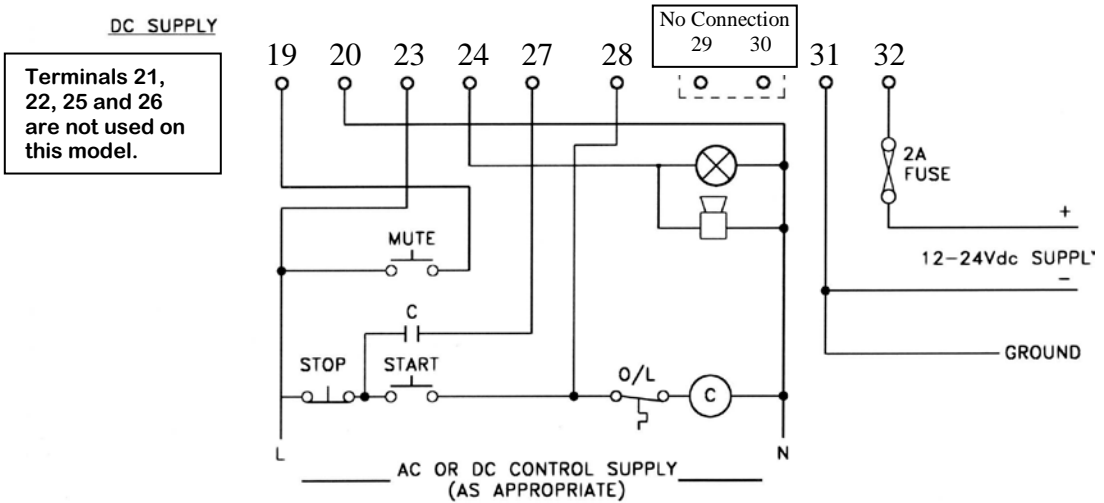

DRG. 'B'

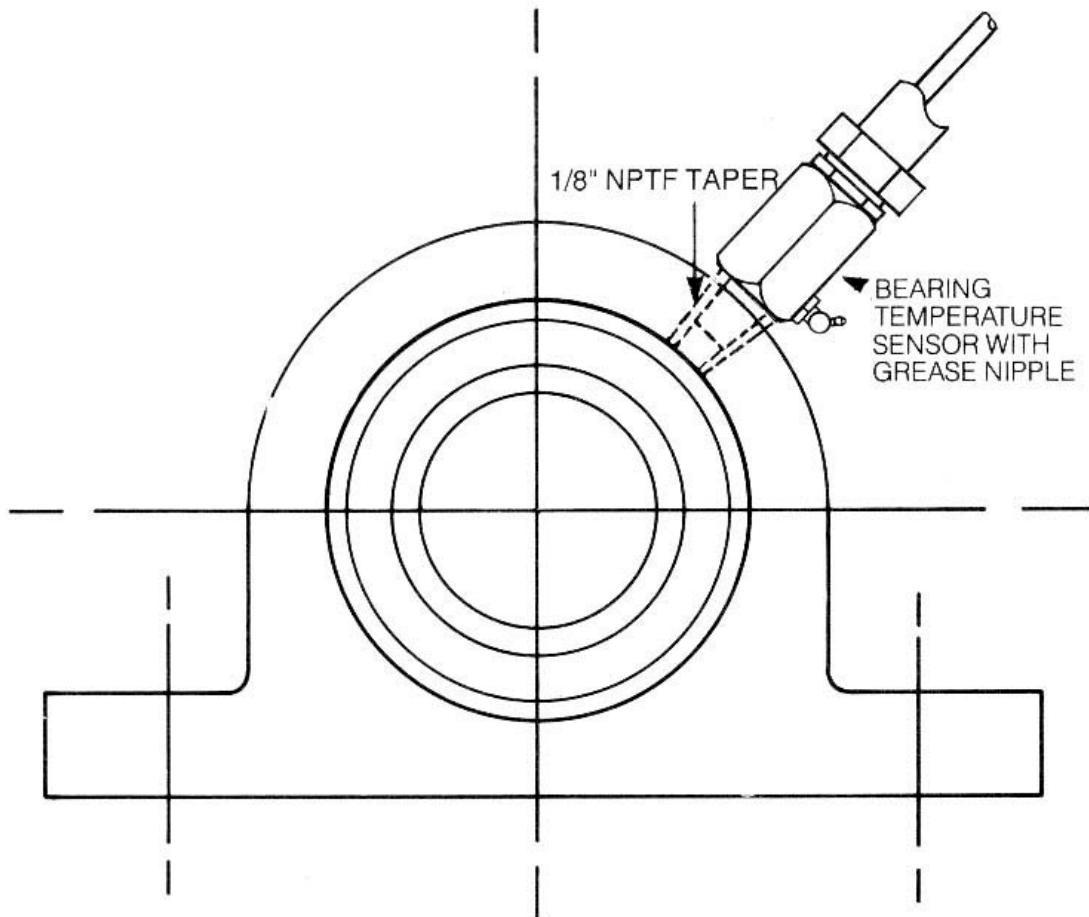

FITMENT TO BEARING OF TEMPERATURE SENSOR

NOTE

The special temperature sensor probe for use in a Class II Division 1 location has a connection for liquidtight flexible metal conduit.

DRG. 'C'

WARRANTY INFORMATION

1. EXCLUSIVE WRITTEN LIMITED WARRANTY

ALL PRODUCTS SOLD ARE WARRANTED BY THE COMPANY (4B COMPONENTS LIMITED, (4B) BRAIME ELEVATOR COMPONENTS LIMITED, AND (4B) S.E.T.E.M. Sarl) HEREIN AFTER REFERRED TO AS 4B TO THE ORIGINAL PURCHASER AGAINST DEFECTS IN WORKMANSHIP OR MATERIALS UNDER NORMAL USE FOR ONE (1) YEAR AFTER DATE OF PURCHASE FROM 4B. ANY PRODUCT DETERMINED BY 4B AT ITS SOLE DISCRETION TO BE DEFECTIVE IN MATERIAL OR WORKMANSHIP AND RETURNED TO A 4B BRANCH OR AUTHORIZED SERVICE LOCATION, AS 4B DESIGNATES, SHIPPING COSTS PREPAID, WILL BE, AS THE EXCLUSIVE REMEDY, REPAIRED OR REPLACED AT 4B'S OPTION.

2. DISCLAIMER OF IMPLIED WARRANTY

NO WARRANTY OR AFFIRMATION OF FACT, EXPRESSED OR IMPLIED, OTHER THAN AS SET FORTH IN THE EXCLUSIVE WRITTEN LIMITED WARRANTY STATEMENT ABOVE IS MADE OR AUTHORIZED BY 4B. 4B SPECIFICALLY DISCLAIMS ANY LIABILITY FOR PRODUCT DEFECT CLAIMS THAT ARE DUE TO PRODUCT MISUSE, ABUSE OR MISAPPLICATIONS, AS AUTHORIZED BY LAW, 4B SPECIFICALLY DISCLAIMS ALL WARRANTIES THAT THE PRODUCT IS FIT OR MERCHANTABLE FOR A PARTICULAR PURPOSE.

3. NO WARRANTY "BY SAMPLE OR EXAMPLE"

ALTHOUGH 4B HAS USED REASONABLE EFFORTS TO ACCURATELY ILLUSTRATE AND DESCRIBE THE PRODUCTS IN ITS CATALOGS, LITERATURE, AND WEBSITES, SUCH ILLUSTRATIONS AND DESCRIPTIONS ARE FOR THE SOLE PURPOSE OF PRODUCT IDENTIFICATION AND DO NOT EXPRESS OR IMPLY A WARRANTY AFFIRMATION OF FACT, OF ANY KIND OR A WARRANTY OR AFFIRMATION OF FACT THAT THE PRODUCTS WILL CONFORM TO THEIR RESPECTIVE ILLUSTRATIONS OR DESCRIPTIONS. 4B EXPRESSLY DISCLAIMS ANY WARRANTY OR AFFIRMATION OF FACT, EXPRESSED OR IMPLIED, OTHER THAN AS SET FORTH IN THE EXCLUSIVE WRITTEN LIMITED WARRANTY STATEMENT ABOVE, INCLUDING, WITHOUT LIMITATION, THE IMPLIED WARRANTIES OF MERCHANTABILITY AND FITNESS FOR A PARTICULAR PURPOSE.

4. LIMITATION OF DAMAGES

ANY LIABILITY FOR CONSEQUENTIAL, INCIDENTAL, SPECIAL, EXEMPLARY, OR PUNITIVE DAMAGES, OR FOR LOSS OF PROFIT WHETHER DIRECT OR INDIRECT, IS EXPRESSLY DISCLAIMED.



DECLARATION OF CONFORMITY

We, the undersigned, on behalf of Don Electronics Limited, hereby declare that the products listed below conform to the relevant provisions of the legislation, as well as pertinent clauses of the standards and other normative documents mentioned herein.

PRODUCT: T4004V4CAI (Enclosure type 864)
TYPE OF PRODUCT: MULTI SENSOR TEMPERATURE MONITOR
INTENDED USE: HOTBUS MONITORING SYSTEM

STANDARDS:

IEC/EN ISO 12199-1 Safety of machinery
IEC/EN61000-6-3 & 6-4 General Emission Standard
IEC/EN61000-6-1 & 6-2 General Immunity Standard
IEC/EN60079-11 Equipment – Intrinsic safety

DIRECTIVE:

94/9/EC ATEX – Electrical Protection by Enclosure

COMPLIANCE:

IEC/EN60079-0:2007 Equipment – General requirements
IEC/EN60079-31:2008 Equipment dust ignition protection by enclosure ‘t’
Ex II 2D Ex tD A21 T125 IP66
Baseefa04ATEX0131X
IECEX BAS 05.0026X
DIP DIP A21 TA125°C IP66 -20°C < ta <+50°C

C22.2

Canadian Standards Association
Class II Division 1 Groups E,F & G

Notified bodies:-

Canadian Standards Association
178 Roxdale Boulevard
Toronto
Canada – M9W 1R3
File number 212693

BASEEFA (CE1180)
Rockhead Business Park
Standen Lane
Buxton
Derbyshire SK17 9RZ

...
Norman Wheat (MD)
United Kingdom 15.Sept.2009

Manufactured by:
Don Electronics Limited, Westfield Industrial Estate,
Kirk Lane, Yeadon, Leeds LS19 7LX United Kingdom
+44(0)845 130 4798

Document Revision History

Date	Rev.	Changes made
27 Nov 2008	1.5	Modified liability and indemnity clauses also added this revision history
September 2009	2.0	Added revised legal and warranty information to the manual Added updated DofC.