

High intensity Rare Earth



Preface:

The Eclipse Pneumag high intensity magnetic separator has been designed to operate in pneumatic conveying lines to provide protection against ferrous & paramagnetic contamination.

The unit comprises of a single double row high intensity magnetic cartridge, which is secured into its housing via quick release toggle clamps. It is these toggle clamps that ensures Even pressure is generated around the unique silicon based metal detectable seal.

The Pneumag can be incorporated into any form of pneumatic conveying line from lean to dense phase and can be installed at any angle from vertical to horizontal. A common installation Location is tanker discharge to inspect incoming materials.

All powders and granular type materials that are dry can be processed through the unit. Pneumag can operate in line pressures of +/- 1 Bar, units are available up to +/- 5 Bar on request, with a maximum processing line speed of 35m/sec.

A lockable tamper proof cover plate is provided to ensure only Authorised personnel have access to the unit.

Cleaning:

The Pneumag benefits from the Eclipse 'Easy Clean' system. Once the unit requires cleaning simply release the quick release Toggle clamps, remove the contaminated cartridge from the housing and remove the magnetic cores from the tube assembly. It is at this stage that all attracted contamination will Be released allowing for inspection or further analysis.

Suitable Products:

Dry powders & granulates.

Suitable Locations:

All.

Benefits:

Easy to clean ■ Tamper poof guard ■ Metal detectable seal ■
 Reduces 'spark' risk ■ Removes micron sized contaminants ■
 Meet audit requirements ■ Rare Earth 7,000 and 9,000 Gauss ■



Technical Data:-

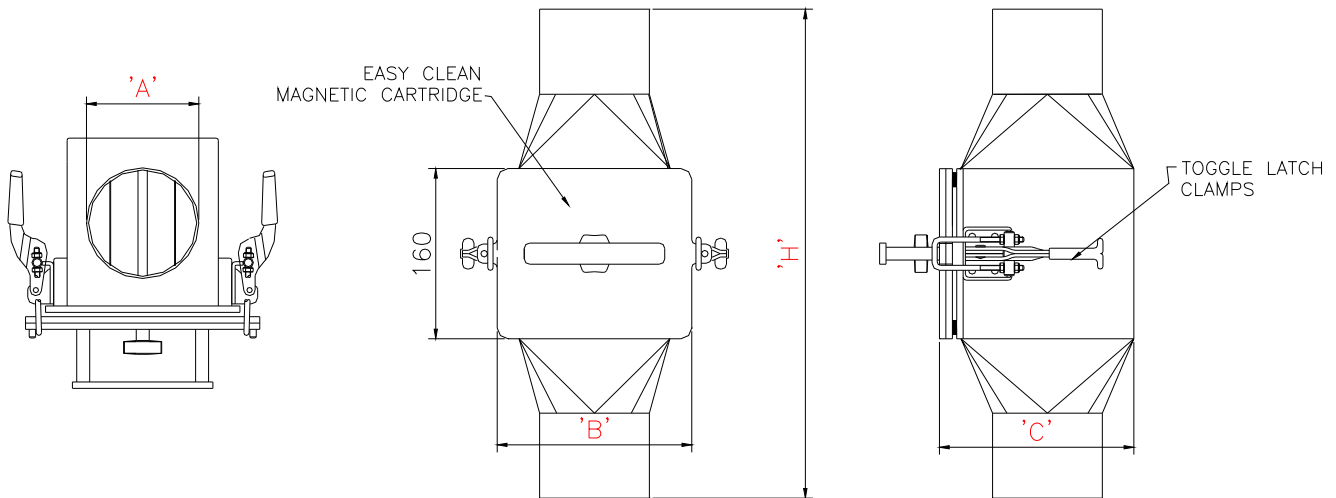

Sizes:-

Part No	Spout Dia A	Width B	Depth C	Height H	No Rods	Weight Kgs
PNEU50	50mm / 2"	150	132	460	3	8
PNEU75	75mm / 3"	180	180	460	4	14
PNEU100	100mm / 4"	180	180	460	4	14
PNEU125	125mm / 5"	240	220	500	6	16
PNEU150	150mm / 6"	240	220	500	6	16
PNEU175	175mm / 7"	290	272	500	8	24
PNEU200	200mm / 8"	290	272	500	8	24

All dimensions in mm

Performance:

Magnetic Performance:

7,000* Gauss Standard Strength
9,000 Gauss High Strength

Performance Reading:

On tube surface

Magnetic Material:

Rare Earth Neodymium Iron Boron

Magnet Grade:

N35 & N45 – Inspected & confirmed via hysteresisgraph prior to use

Temperature:

-20° C / + 60° C

Pressure:

+/- 1 Bar

*7,000 Gauss should be selected for bread flour applications to allow for permissible Iron Oxide.

Materials:

Housing:

316 Grade Stainless Steel

Tubing:

316 Grade Stainless Steel – Aerospace Quality

Other Parts:

316 Grade Stainless Steel

Surface Finish:

Brushed internally/externally to 1.2µm

Sealing:

Metal detectable Silicon rubber – Dark blue

Toggle Clamps:

Mild Steel – Bright Zinc plated

Options:

Stainless Steel toggle clamps

High temperature Samarium Cobalt magnetic material - 250° C

11,000 Gauss fixed grid

Overpressure to +/- 5 Bar

Double magnetic core arrangement

304 Grade Stainless Steel

ATEX certified

Pharmaceutical specification

Safety relay switch

Flanged to suit

March 2008.